



# RHINO-RACK

**CONTROLLED**

**Toyota Tacoma RTTB1**

**BACKBONE**

**Important:** Please read these instructions carefully prior to installation. Please refer to your fitting instruction to ensure that the Backbone System is installed in the correct location. Check the contents of kit before commencing fitment and report any discrepancies. Place these instructions in the vehicle's glove box after installation is complete.

## Layout

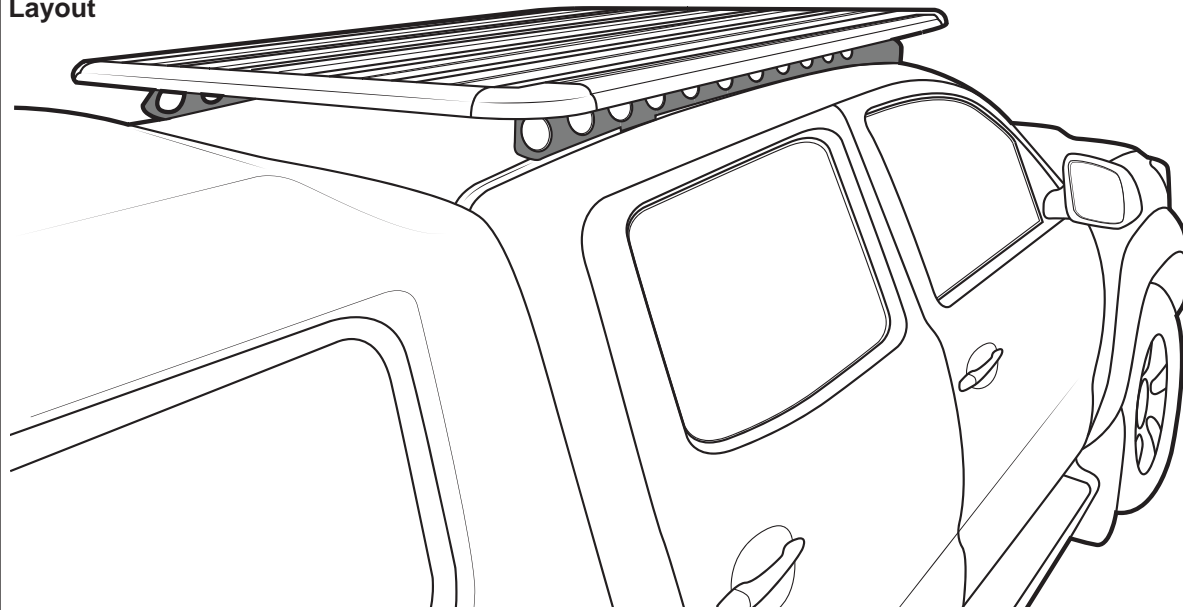

**Maximum load carrying capacity: 100kg / 220lbs**

## Important Information

1.  Check Part No./Kit is correct
2.  Read through instruction before installing
3.  Fit roof rack accessory
4.  Check and recheck all fasteners are secure

**Maximum carrying capacity:** 100kg (220lbs) including the weight of the rack system up to 25kg/55lbs (dependant on Platform size). Please refer to your vehicle manufacturers handbook for maximum carrying capacity. Always use the lower of the two figures. Load must be evenly distributed over the entire basket. **Static Load Rating: 320kg/ 705lbs**

**Warning:** Do not attempt to fit the rack system to your vehicle unless you fully understand these fitting instructions. Please direct any questions regarding fitting to the dealer from where the roof racks were purchased.

**Use only non-stretch fastening ropes or straps.**

**Recommendations:** It is essential that all bolt connections be checked after driving a short distance when you first install your roof racks. Bolt connections should be checked again at regular intervals (once a week is enough, depending on road conditions, usage, loads and distances travelled). You should also check the roof racks each time they are re-fitted. Always make sure to fasten your load securely. Please also ensure that all loads are evenly distributed and that the centre of gravity is kept as low as possible and must be entirely contained within the extents of the roof racks.

**Rack System must be removed when putting vehicle through an automatic car wash.**

**Caution:** The handling characteristics of the vehicle changes when you transport a load on the roof. For safety reasons we recommend you exercise extreme care when transporting wind-resistant loads. Special consideration must be taken into account when cornering and braking.

### Off-road use:

The Backbone Rack System may be used in off road applications, however a safety factor of 1.5 is enforced. That is, maximum permissible off road load is **66kg (145lbs)**. Although the crossbars are tested and approved to AS1235-2000/ 15011154, off-road conditions can be much more rigorous. Extreme care must be taken in off road conditions

### Note for Dealers and Fitters:

It is your responsibility to ensure these fitting instructions are given to the end user or client.

Rhino-Rack 3 Pike Street, Rydalmere,  
NSW 2116, Australia.  
(Ph) (02) 9638 4744  
(Fax) (02) 9638 4822

Document No: R989  
Prepared By: Kayle Everett  
Authorised By: Chris Murty

Fit Time: 1 Hours  
Issue No: 01  
Issue Date: 22/07/2016

These instructions remain the property of Rhino-Rack Australia Pty. Ltd. and may not be used or changed for any other purpose than intended.



# Toyota Tacoma RTTB1

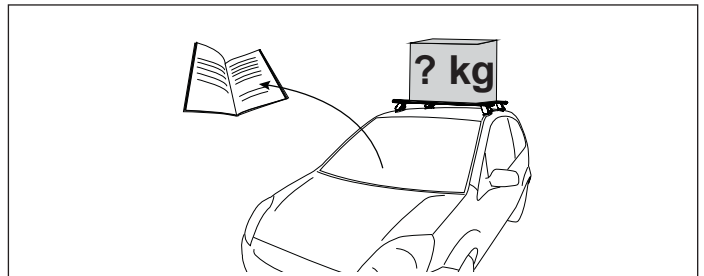
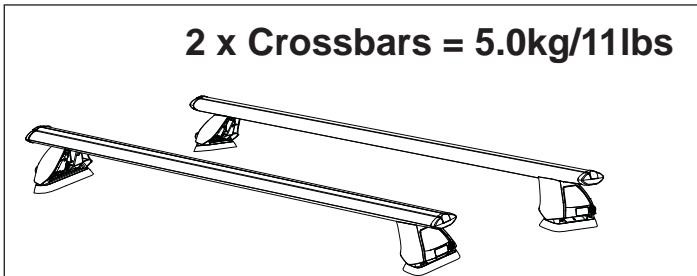
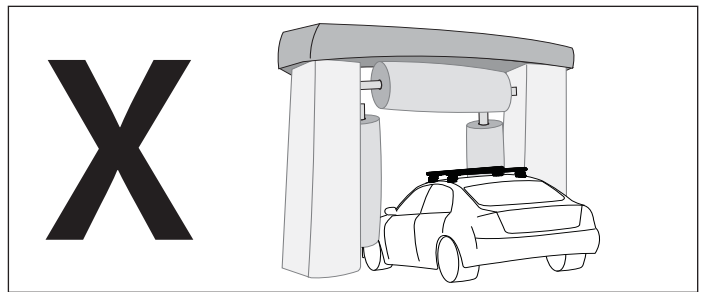
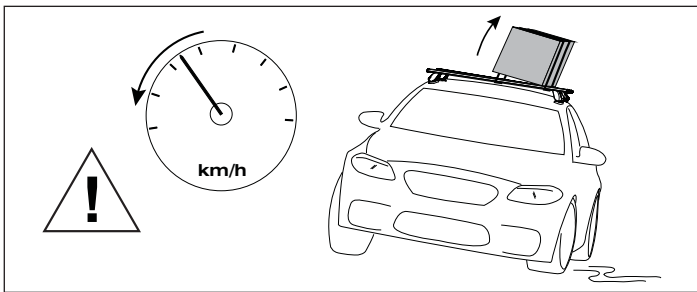
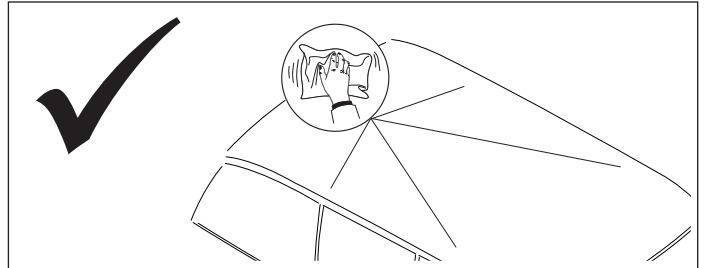
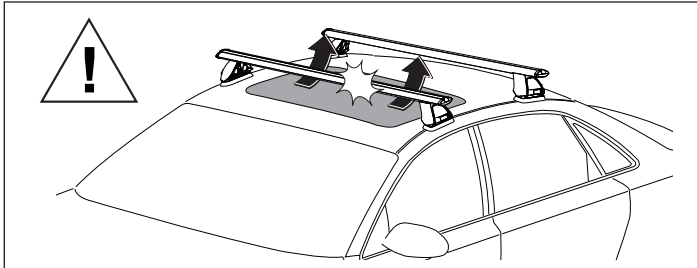
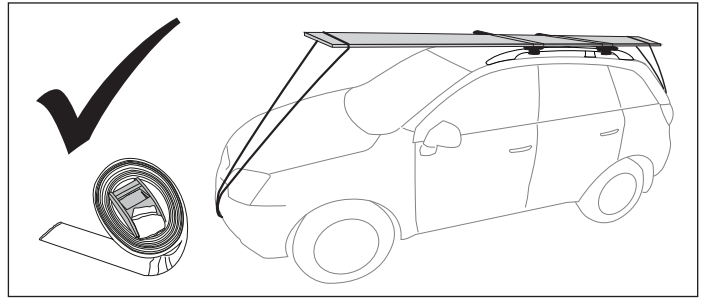
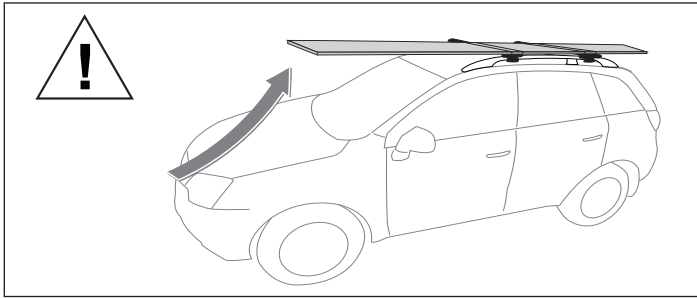

When these roof racks are to be used on a vehicle that is driven off sealed roads, the manufacturer maximum roof load rating (to be found in the vehicles User Manual) should be **divided by 1.5**. Do not forget to subtract the complete crossbar system weight from your maximum carrying capacity.

100kg/220lbs (Urban Road)	=	66kg/145lbs (Off Road)
------------------------------	---	---------------------------

**Static Load Rating: 360kg/ 800lbs**

**Ensure Ladder is well supported on the ground to help support tent. Take extreme caution when climbing heights above 1.2m/4ft.**

Paddle/ Surfboards should be fixed to the front of the vehicle.

**YES**



## Parts List

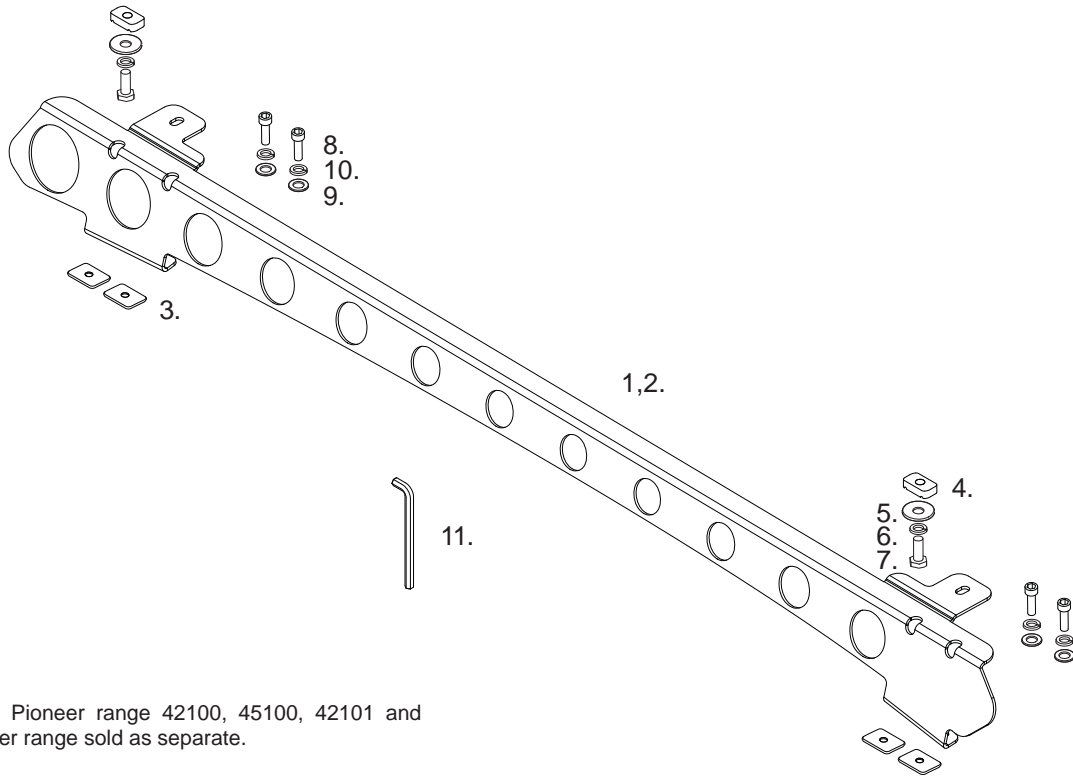

For use with Pioneer range 42100, 45100, 42101 and 45101. Pioneer range sold as separate.

Item	RTL B1 Kit	Qty	Part No.
1	Tacoma LH Backbone	1	CA1501
2	Tacoma RH Backbone	1	CA1502
3	Butyl Patch 20x20mm 5mm Hole	8	CA1266
4	M8 Channel Nut	4	N003
5	M8x19x2.5 Flat Washer	4	W043
6	M8 Spring Washer	4	W019
7	M8x25 Hex Setscrew	4	B169
8	M6x20 Socket Head Screw	8	B163
9	M6 x 18mm Flat Washer	8	W031
10	M6 Spring Washer	8	W019
11	Short 6mm Allen Key	1	H050
12	Instructions	1	R989

### Tools Required:

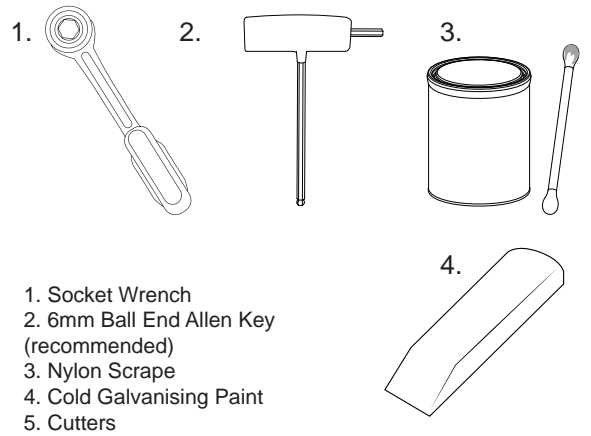

- Starting at the front of the vehicle, carefully lift out the Ditch Mould. Be sure Ditch is clean.

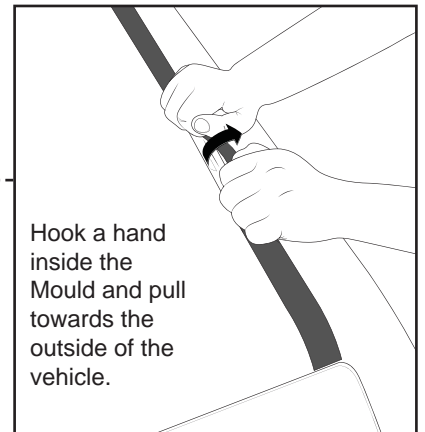
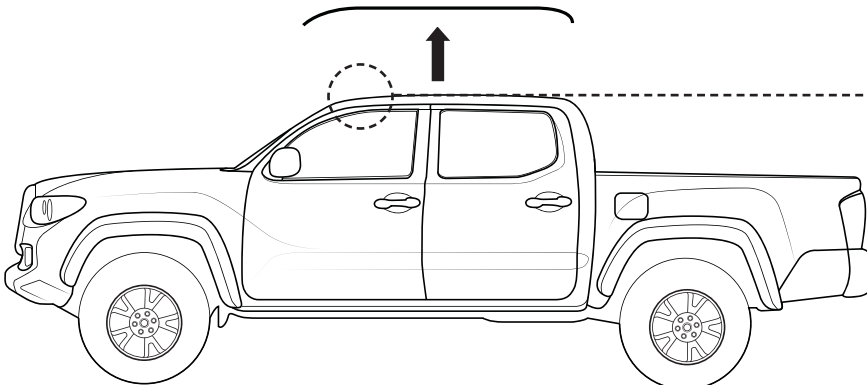

Hook a hand inside the Mould and pull towards the outside of the vehicle.



# Toyota Tacoma RTTB1



**2** Locate the Painted Butyl Patches within the Ditch. With a Nylon Scrape, carefully remove the Patches both front and rear.

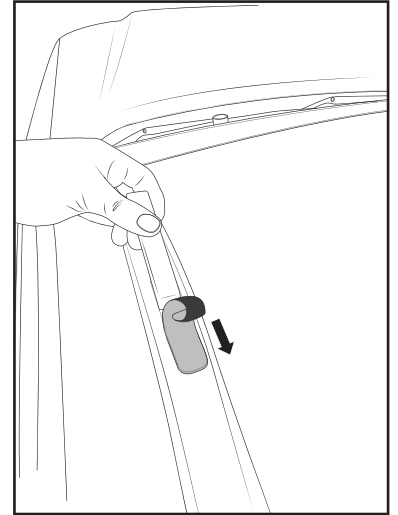
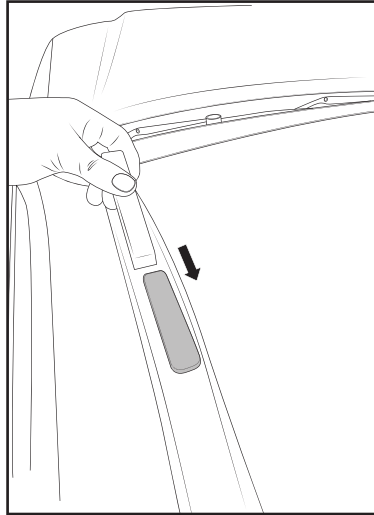
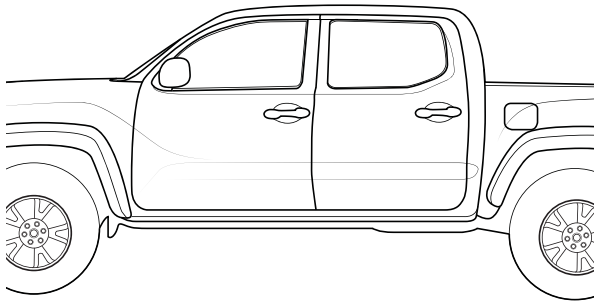

**3** Use Cold Galvanising Paint to cover the newly exposed area. It is imperative that all body work is covered.

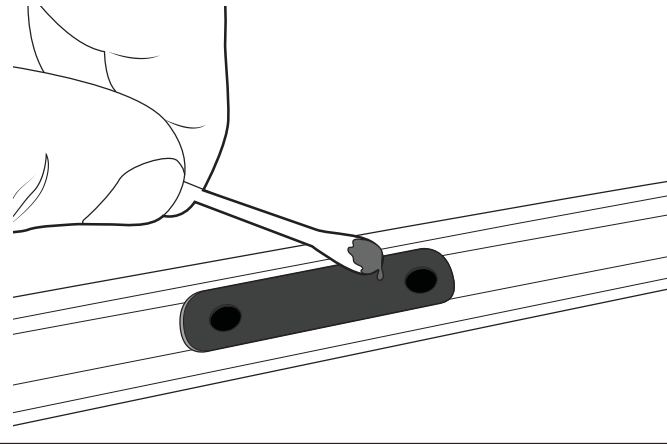

**4** Test exposed threads with M6 Screws. Remove any material causing binding.

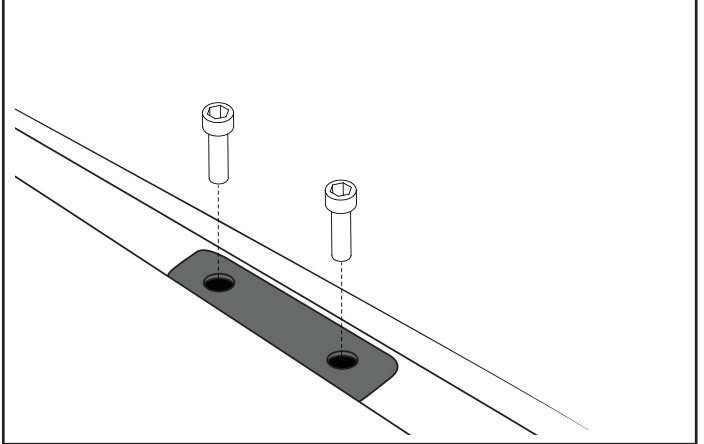

**5** Remove one side of protective tape from the Butyl Patches provided. Place carefully over the exposed threads. Remove the top layer of protective tape from the installed Patches.

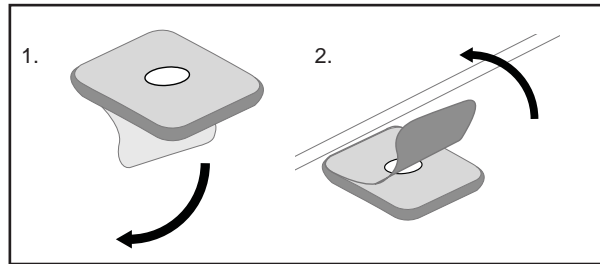
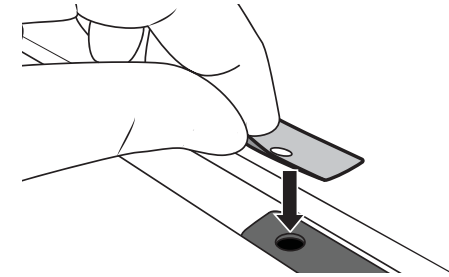

**6** Place one side of the Backbone onto the roof of the vehicle. Line up the mounting points of the bracket to the those exposed on the roof in the previous steps.

Front View:

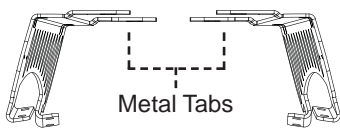

Metal Tabs

Metal Tabs face in toward the vehicle.

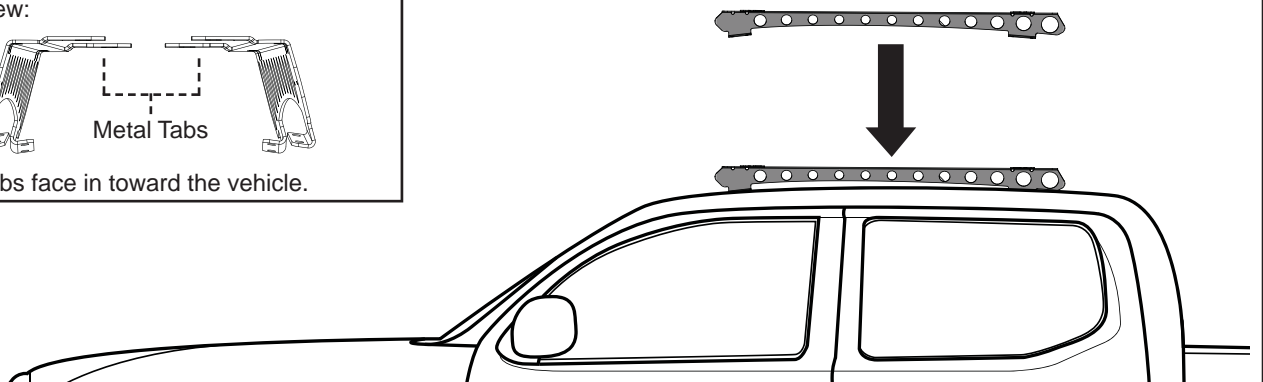



# Toyota Tacoma RTTB1



**7** Using the M6 Socket Screws, M6 Spring and Flat Washers, place the hardware into mounting holes of rails. Make sure hardware and holes align with roof mounts before proceeding to Step 8.

**8** Start carefully securing the Backbone by tightening the M6 socket hardware into the roof fixed mount points with a 6mm Ball End Allen Key.

Note: Turn the Allen Key carefully and be sure not to damage the Socket Head Screw. You will not be able to completely tighten the Screws.

**9** After all bolts have been tightened as much as possible with the Ball End Allen Key - tighten completely using the Small 6mm Allen Key that is provided with the kit.

**10** Repeat steps 2-10 for securing opposite side Backbone rail.

Ensure both Backbones are securely positioned on the car. Check each bolt before proceeding to attaching the Pioneer tray to the Backbone Rails.

**11** Assemble M8 Hardware as pictured below. Complete this for the four tabs on top of the backbone rails (two each rail).

Note: For easy Pioneer installation. Align as shown

**12** Install Pioneer Underbars with slots indicated (42100, 45100, 42101 or 45101).

**REAR:** 125mm from Rear (using slots)  
**FRONT:** 100mm from Front (drill)

The rear slot will have to be drilled with an 8.5mm drill bit. For detailed underbar installation instructions, refer to Pioneer fitting instructions.



# Toyota Tacoma RTTB1

# BACKBONE

**13** After Underbars have been correctly fitted, place the Pioneer tray on top of the Backbone. Align the Underbars with the top tabs and ensure the M8 hardware fits into underbar channel.

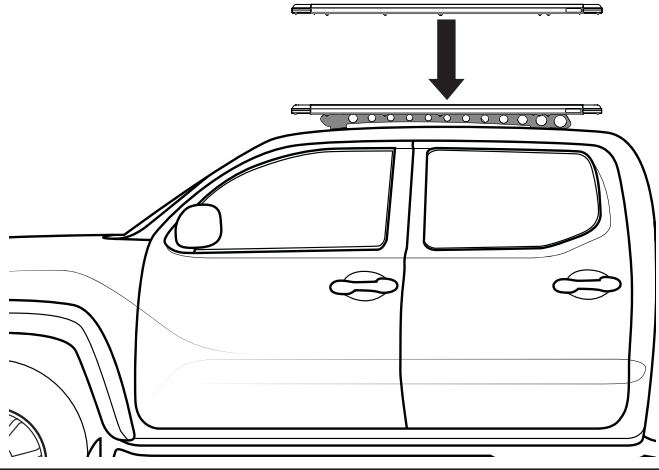

**14** Once Pioneer Underbars have been aligned properly, tighten all M8 hardware using 13mm (1/2") Socket Wrench or 13mm (1/2") Spanner. Ensure channel nut has rotated within Pioneer underbar and is fixing Pioneer securely.

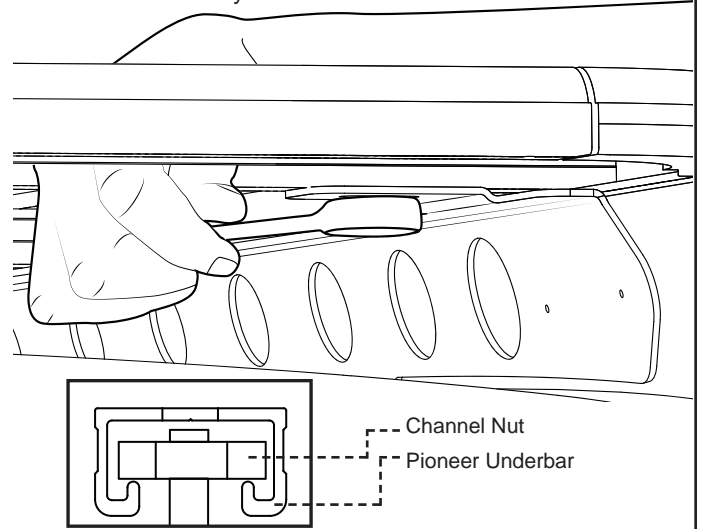

**15** The Ditch Rubber can cut and refit on either side of the Backbone.

